

M* = Lavakiinnikkeen pohjaan/To the bottom of the body bracket.
 N* = Lavakiinnikkeen pohjasta z-palkin pohjaan/
 From the bottom of the body bracket to the bottom of the z-beam.

Tarkemmat asennusmitat piirustuksesta 300209200/
 More detailed mounting dimension on drawing 300209200

Ø Vaihe / Stage	Isku / Stroke mm
132	580
115	586
100	586
85	586
70	588
55	606
Yht/Total	3532

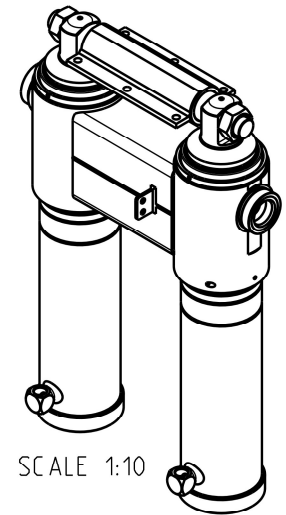
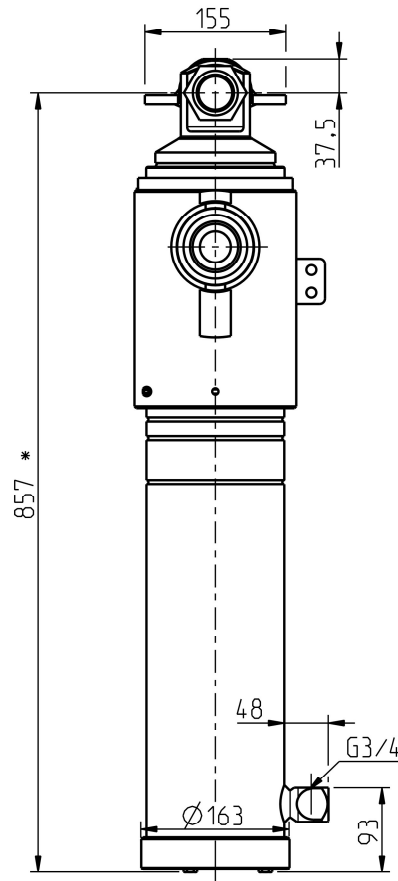
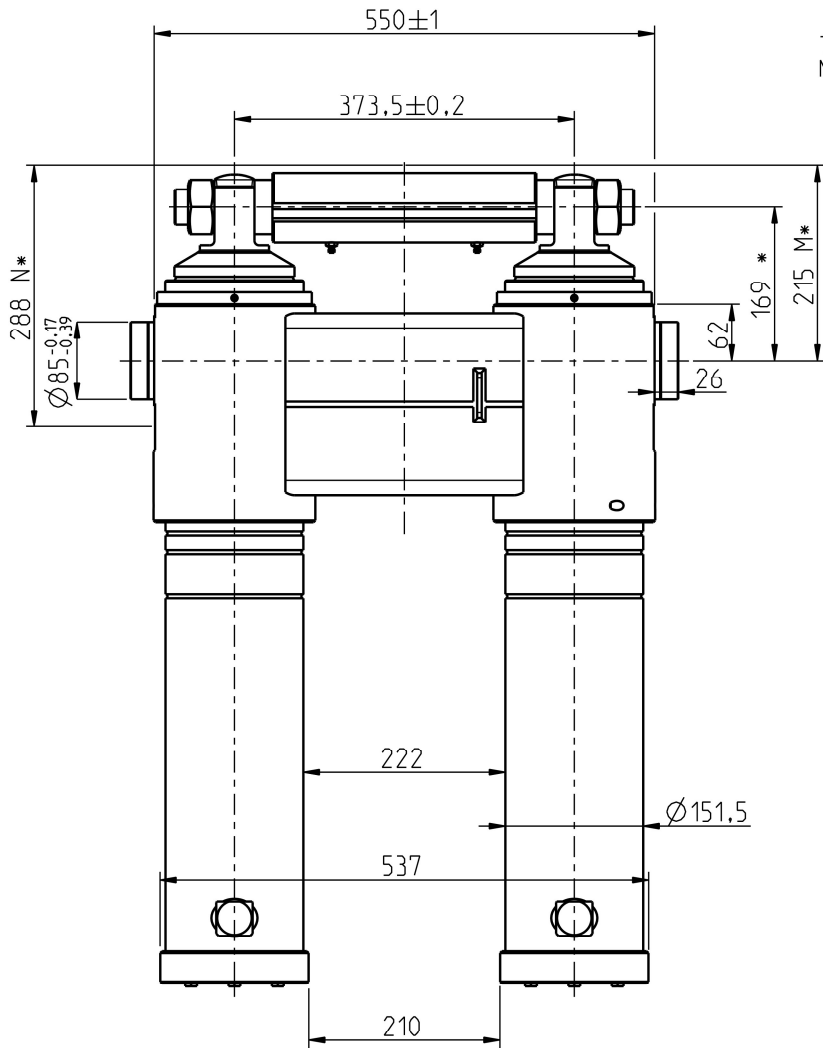

SCALE 1:10

Iskutilavuus / Stroke volume 51.4 dm³

Max. paine / pressure 250 bar (25 MPa)

Max. kuorma / load 50 t

* Asennusvara / Recommended mounting space min. 15 mm

Date	Drawn	Revision		
		Piirt Drawn	TDa	GENERAL TOLERANCE : ISO 2768-m
		Pvm Date	21.09.23	THREAD TOLERANCE : ISO 965-3/ISO 228-1
		Koko Size	A3	WELD ACCORDING TO: ISO 5817
		Liittyy / Belongs to		Material
		RTF 59 50†		--
		Nimitys	SRYHMÄ 152/ 55x3532	Suhde/Scale
		Name	TWIN RAM 152/ 55x3532	Revision
				17:100
				-
				Piirustus no / Drawing no
				310210131

