

Vaihe/Stage	Isku/Stroke (mm)
Ø194	286
Ø172	295
Ø152	298
Ø132	300
Ø115	286
Ø100	237
Ø85	254
Ø70	250
Yht./Sum. =	2206

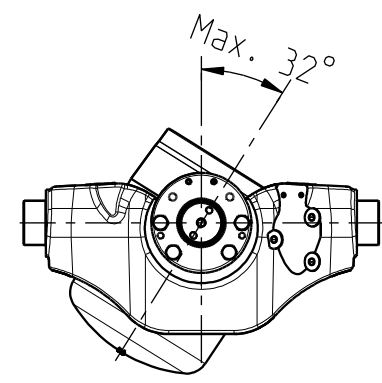
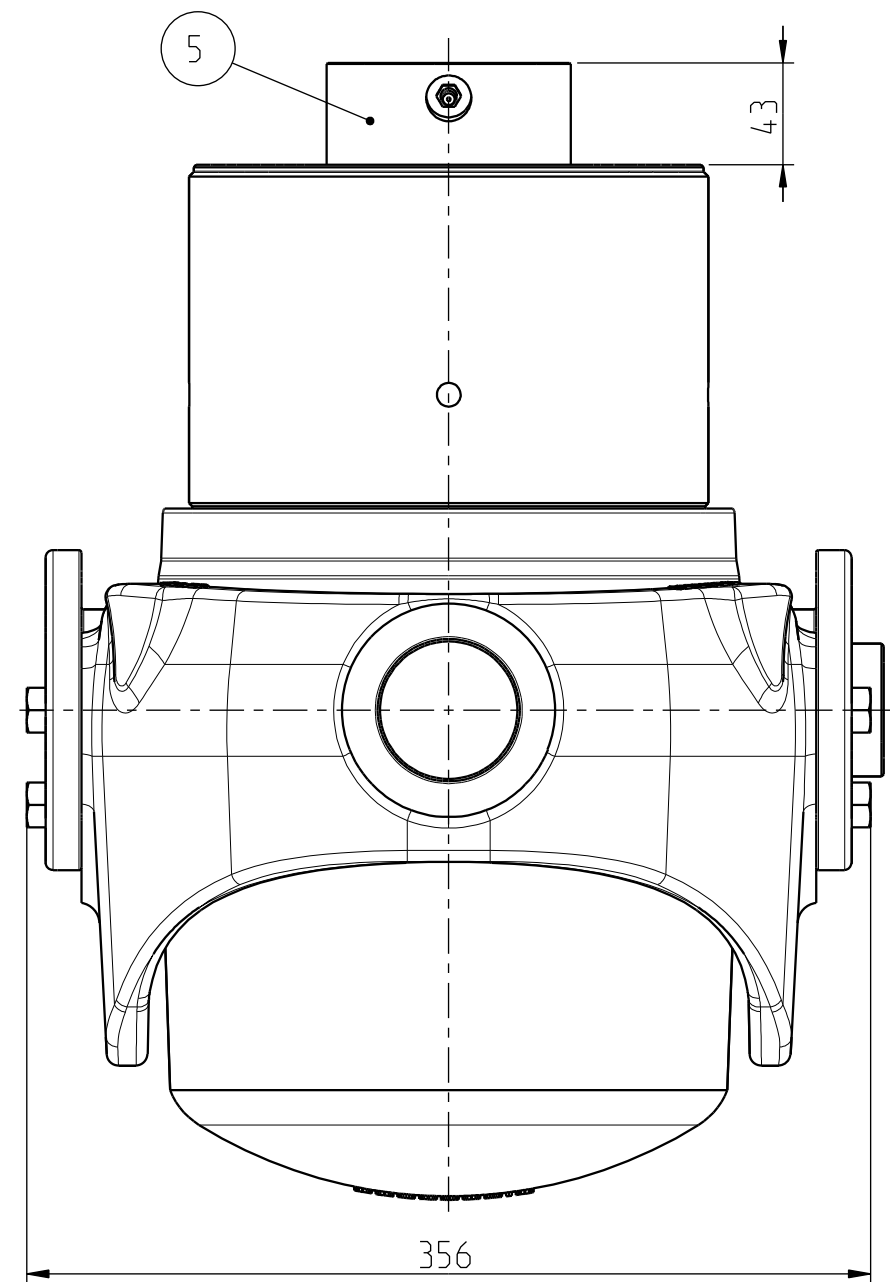

Öljy-yhde / Oil inlet G3/4"

Öljy-yhde samalle puolelle rajoitin kierteiden kanssa / Oil inlet to the same side with knock-off threads.

M12 ruuvien kiristysmomentti / Tightening torque of the M12 screws 115 Nm.

Max. Paine / Pressure 280 bar (28 MPa).

Max. Kuorma / Load 30 t.

Iskutilavuus / Stroke volume 32.1 dm³

* + Asennusvara / Mounting space 15 mm.

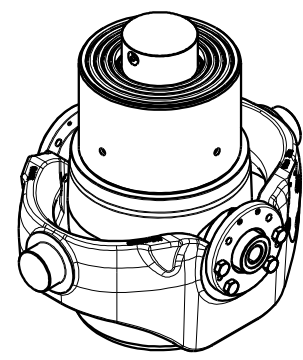

26.11.18	VSS	a1) paine/pressure 280 bar.		
Date	Drawn	Revision		
		Piirtä Drawn JMe	GENERAL TOLERANCE: ISO 2768-m	Koodi Code -
		Pvm Date 21.04.10	THREAD TOLERANCE: ISO 965-3/ISO 228-1	Paino (kg) Weight 144.646
		Koko Size A3	WELD ACCORDING TO: ISO 5817	Material STD -
Liittyy / Belongs to				Material
SUT27 HP				-
Nimitys				Suhde/Scale Revision
NY SUT27 194-8-2206				33:100 A
Name				Piirustus no / Drawing no
LU SUT27 194-8-2206				310207269